



Supporting board I, Integral Type



Supporting board II, Separate Type



Supporting board III, Frame type

Type	TL30	TL45	TL65	TL80	TL95	TL115	TL125	TL155	TL180	TL225	TL250	
Reference												
Pitch	t	30	45	65	80	95	115	125	155	180	225	250
Bending radius	R	20	50, 75 90, 114, 145	75, 90 115, 125 145, 185	100, 115 125, 145 185, 200 250, 300	114, 145 200, 250 300	145, 200 225, 250 300, 350	200, 250 300, 350 470, 500 575, 700, 750	200, 250 300, 350 450, 500 600	250, 300 350, 450 490, 600 650	400, 450 600, 750 800, 850 1000	400, 450 500, 600 750, 800 1000
Minimum width of drag chain	B mix	40-100	35	50	55	60	70	80	90	100	160	190
Height of drag chain	L	25	32	49	56	75	86	96	120	144	200	220
Max. hole diameter of support plate	D1	-	-	32	35	50	63	75	97	110	146	166
Non-support range		3	4	5	8	9	10	10	10	10	12	14
Type		III	III	I, II, III	II, III	I, II, III	II, III	I, II, III	II, III	II, III	II, III	II, III

1. Drag chains are produced by using Italian technology.
2. When non-standard bend radius or non-standard drag chains are required, we can make them according to the user's requirements.
3. When the max. width Bmax is exceeded, compound type drag chains that consist of 3 chain crawlers can be used. See figure below.

Selection of Drag Chains

1. The hole diameter of the inner cavity of supporting board $D1 = d + \approx 0.1d$ (take round number). where, d = outside diameter of cables, wires, liquid/gas hoses.
2. The height of the supporting board and the model number TLXX of drag chains depends on the the max. hole diameter of the inner cavity of the supporting.
3. The bend radius depends on the functions of the drag chains.
 - (1). When there is a large load from larger calibre or cables on the drag chains, high strength model I supporting board (integral) should be used.
 - (2). When the size of the connectors are greater than that of the hole diameter of the inner cavity of supporting board or frequent assembly or dismantal operations are required, type III supporting board (frame type) can be used.
4. The width of supporting board B, can be decided according to the quantity of the cables installed so that the width of the drag chain B can be arrived.
5. When limited by locations or environment and if bracing board with steel straps are needed, please contact our company for solutions.

Drag chains with 3 chain board

One or more drag chain boards can be installed on a wider drag chain, because the max. length of the supporting board is 600mm-650mm. This arrangement can also improve the stability of the narrower chains. In this way, the conduit and the cables can be separated from one another by a third chain board.

Note: Parameters D, 12, e be used for GLE type and f,j,k for TL type.

Elastic status for hydraulic pipes

Note that the pressure of a hydraulic pipe may extend or contract downward, so the elasticity should be taken into consideration, especially under high pressure or with long length.

TL series steel drag chains

TL series drag chains are mainly consisting of chain plate (top quality stainless steel with chromium plated), supporting board (extruded aluminium alloy) and pinshaft (alloy), etc. There is no relative motions between the cables/rubber hoses and the drag chains, giving no deforming or twists. The chromium plated chain board has very nice-looking appearance and has very rational construction and flexible and high strength. It is reliable and easy to operate, install, dismantal or assemble. It is worthwhile mentioning that the anti-wearing performance has been improved greatly due to wear resistant material and alloy pinshaft are used. The product is flexible to bending and has low resistance, giving low noises. It can be used for a very long period of time without any deformation or hanging down. The product is nice-looking, which makes the machine tool unit nicer looking as a whole and makes the machine tools and machineries more competitive in the international market.

1. The drag chain can adapt to max. moving speed of 40m/sec.
2. When at the max moving speed, the sound pressure of noises shall not be greater than 68 db.
3. The service life of the drag chain shall not be less than 1 million times (reciprocating).

TL30

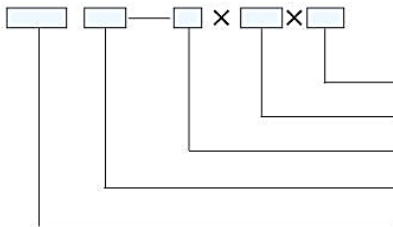
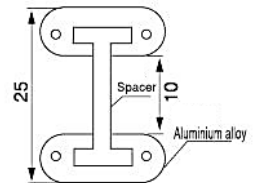
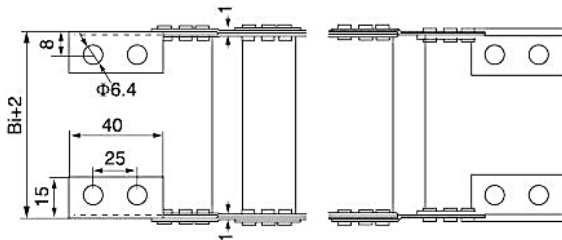
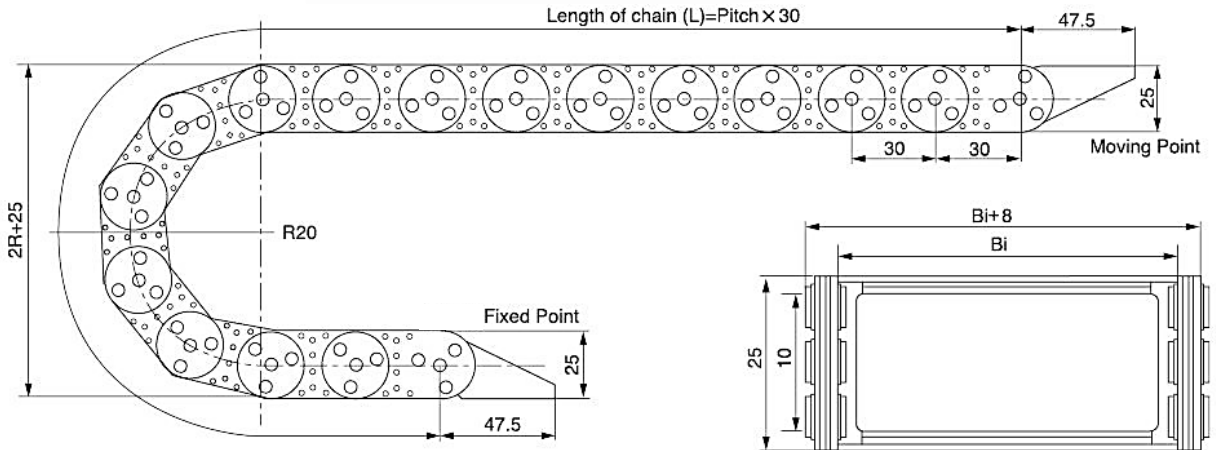

Legends:

- L = length of drag chains
- Bi = Width of supporting board of drag chain
- Bending radius
- Supporting Board Type III
- Model No.

Example for an order

Drag chain model number TL30, supporting board III type, bend radius R=30, length L=5500
 Drag chain TL30Ⅲ-30 × 5500
 Ⅲ-type The upper one and the lower one are made of aluminium with spacer inside

TL45

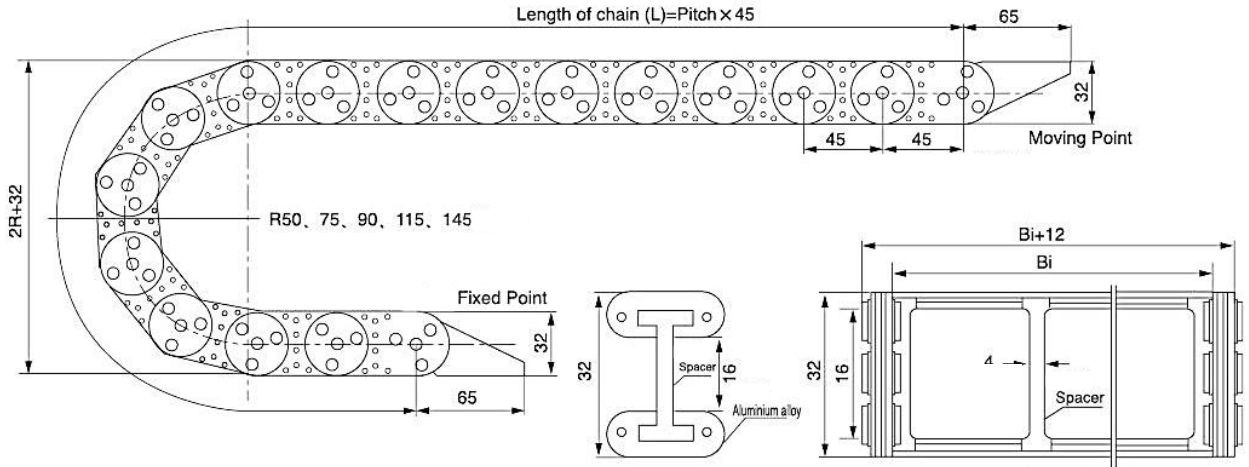

Supporting board III. Frame type

Standard connection

Standard connection

Manner of connection A

Manner of connection B

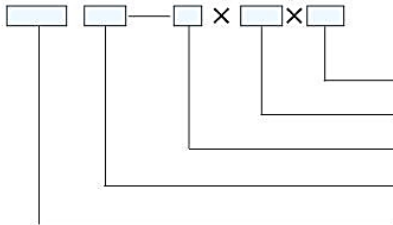
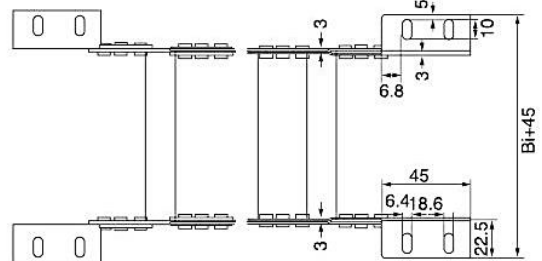
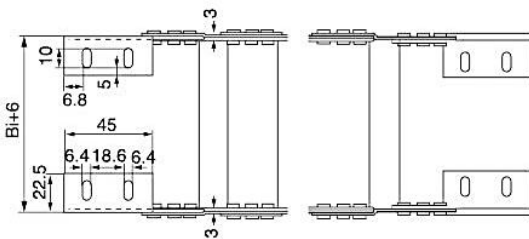

Lengends:

- L = length of drag chains
- Bi = Width of supporting board of drag chain
- Bending radius
- Supporting Board Type III
- Model No.

Example for an order

Drag chain model number TL45, supporting board III type, bend radius R=90, length L=5500
 Drag chain TL45III-90 × 5500
 III-type The upper one and the lower one are made of aluminium with spacer inside

TL65

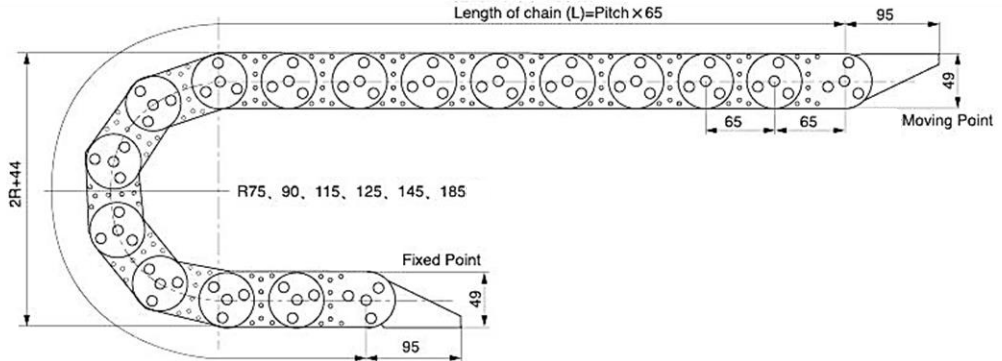

I Integral type,
II Separate type

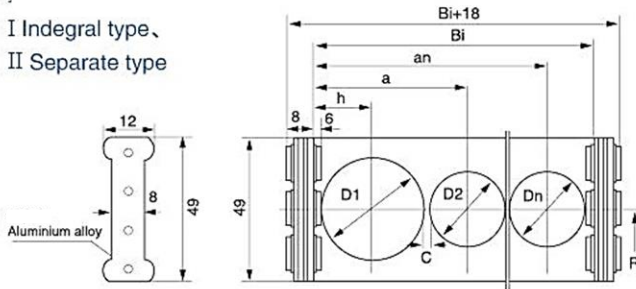

Supporting board I Integral type, II Separate type

III Frame type

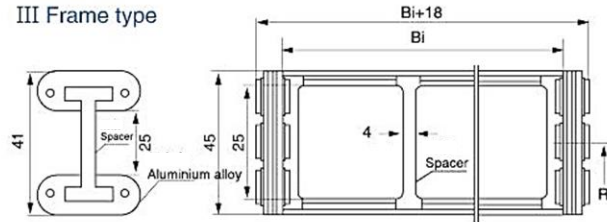

Supporting board III, Frame type

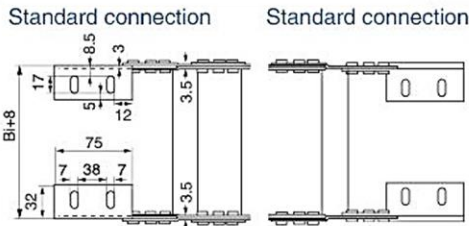

Manner of connection A Manner of connection B

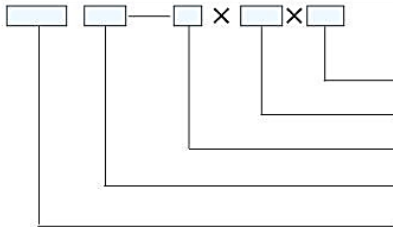
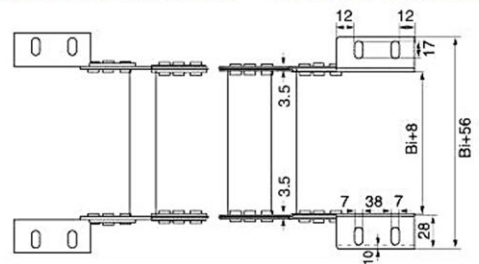

L = length of drag chains
Bi = Width of supporting board of drag chain
Bending radius
Supporting Board Type I、II、III
Model No.

Example for an order
Drag chain model number TL65, supporting board III type, bend radius R=115, supporting board width Bi=200 length L=6500
Drag chain TL65III-115 x 200 x 6500
I -type Integral type of support board
II -type Separate type of support board
III -type The upper one and the lower one are made of aluminium with spacer inside

unitmc.ru

TL80

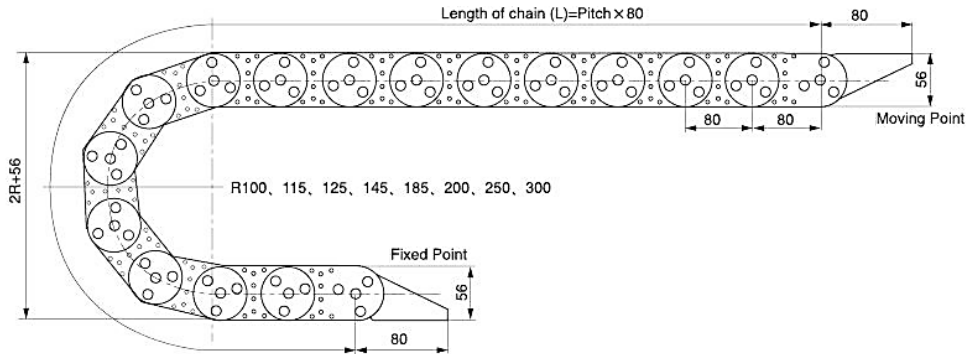

I Integral type,
II Separate type

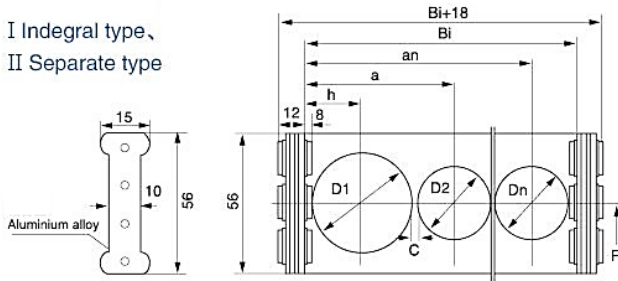

Supporting board I Integral type, II Separate type

III Frame type

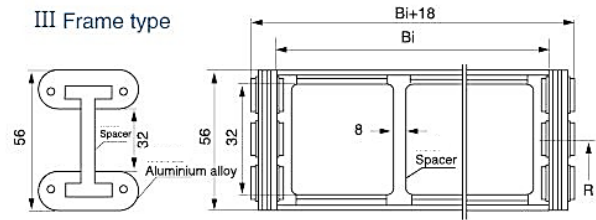

Supporting board III, Frame type

Standard connection

Standard connection

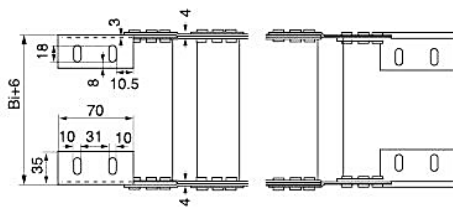

Manner of connection A

Manner of connection B

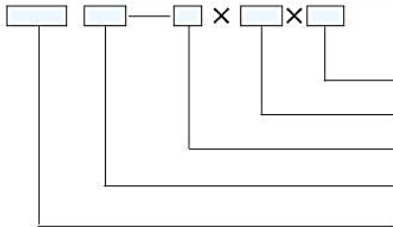
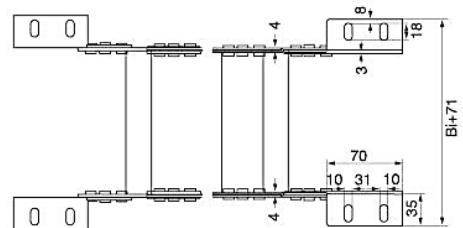

- L = length of drag chains
- Bi = Width of supporting board of drag chain
- Bending radius
- Supporting Board Type I、II、III
- Model No.

Example for an order

Drag chain model number TL85, supporting board III type, bend radius R=125, supporting board width Bi=200 length L=6500

Drag chain TL85 III-125 x 200 x 6500

I -type Integral type of support board

II -type Separate type of support board

III -type The upper one and the lower one are made of aluminium with spacer inside

TL95

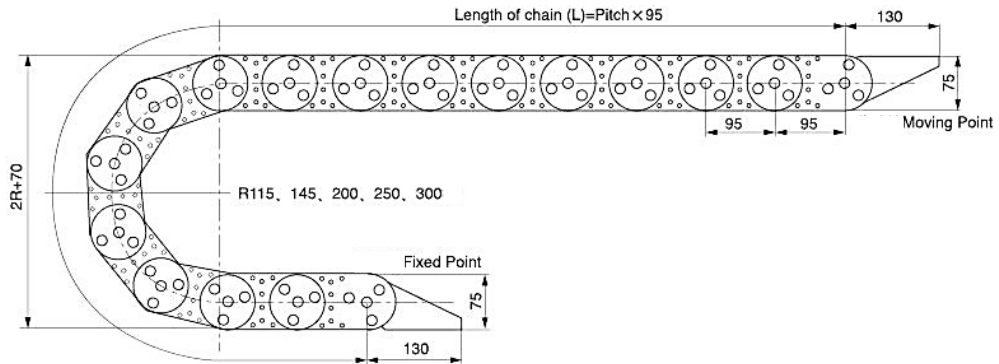

I Integral type,
II Separate type

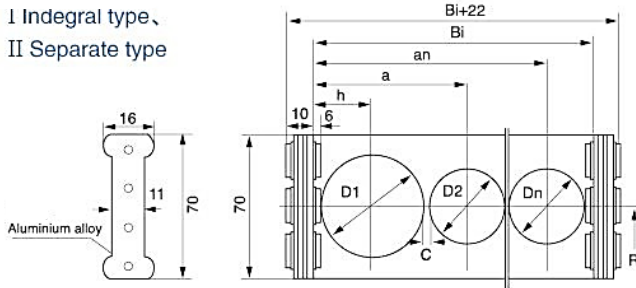

Supporting board I Integral type, II Separate type

III Frame type

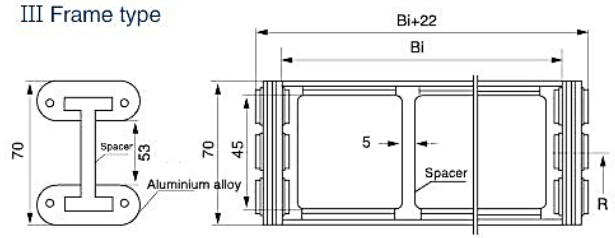

Supporting board III, Frame type

Standard connection

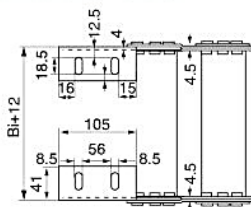

Standard connection

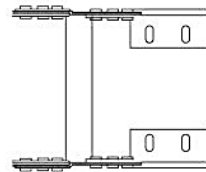

Manner of connection A

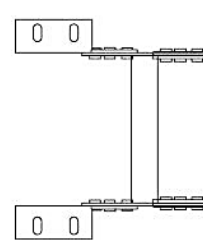

Manner of connection B

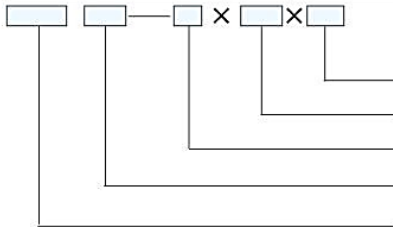
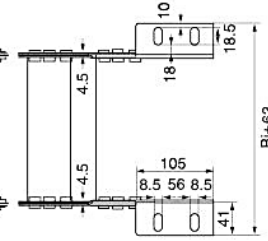

- L = length of drag chains
- Bi = Width of supporting board of drag chain
- Bending radius
- Supporting Board Type I、II、III
- Model No.

Example for an order
 Drag chain model number TL95, supporting board III type, bend radius R=250, supporting board width Bi=300 length L=7500
 Drag chain TL95 III-250 x 300 x 7500
 I -type Integral type of support board
 II -type Separate type of support board
 III -type The upper one and the lower one are made of aluminium with spacer inside

unitmc.ru

TL115

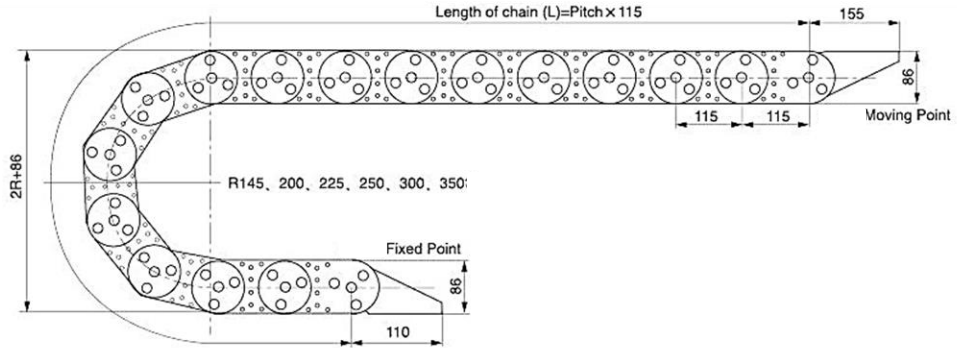

I Integral type,
II Separate type

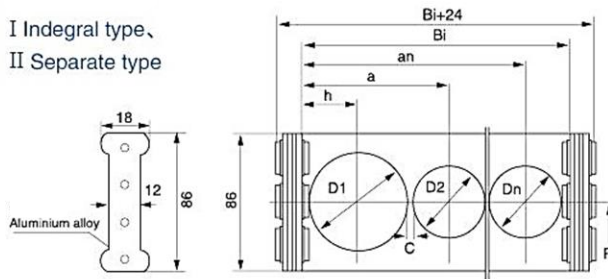

Supporting board I Integral type, II Separate type

III Frame type

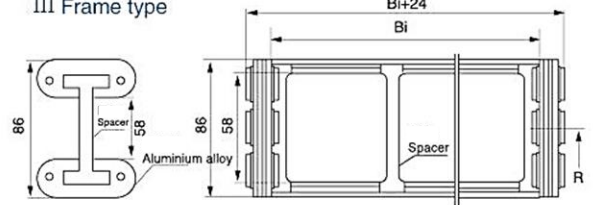

Supporting board III, Frame type

Standard connection

Standard connection

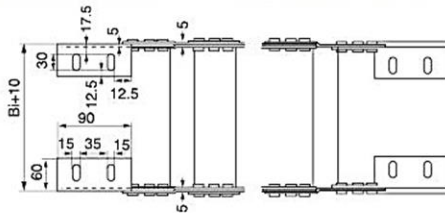

Manner of connection A

Manner of connection B

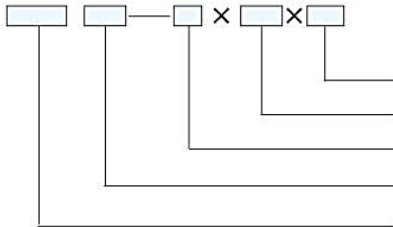
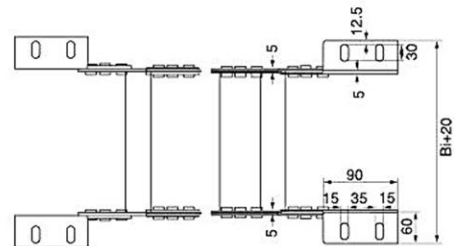

- L = length of drag chains
- Bi = Width of supporting board of drag chain
- Bending radius
- Supporting Board Type I、II、III
- Model No.

Example for an order
 Drag chain model number TL115, supporting board III type, bend radius R=250, supporting board width Bi=300 length L=7500
 Drag chain TL115 III-250 x 300 x 7500
 I -type Integral type of support board
 II -type Separate type of support board
 III -type The upper one and the lower one are made of aluminium with spacer inside

unitmc.ru

TL125

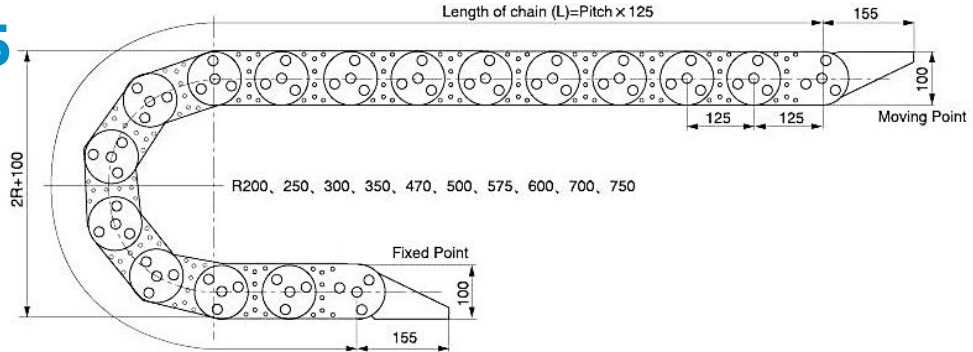

I Integral type,
II Separate type

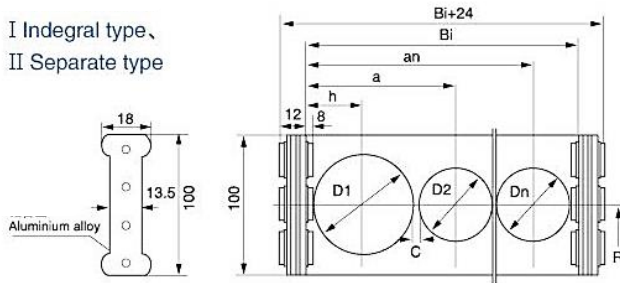

Supporting board I Integral type, II Separate type

III Frame type

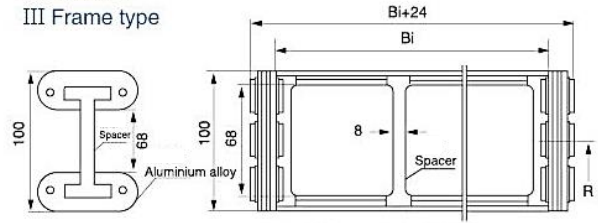

Supporting board III, Frame type

Standard connection

Standard connection

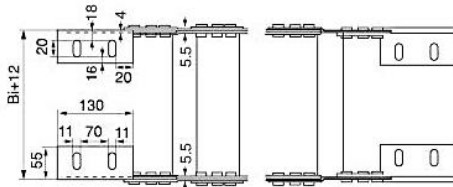

Manner of connection A

Manner of connection B

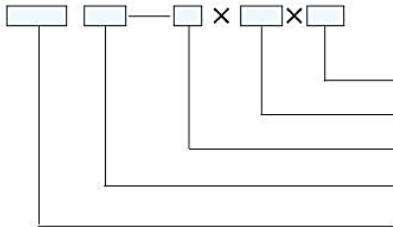
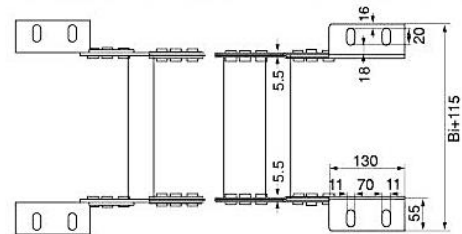

L = length of drag chains
Bi = Width of supporting board of drag chain
Bending radius
Supporting Board Type I、II、III
Model No.

Example for an order

Drag chain model number TL125, supporting board III type, bend radius R=250, supporting board width Bi=300 length L=7800
Drag chain TL125III-250 x 300 x 7800
I -type Integral type of support board
II -type Separate type of support board
III -type The upper one and the lower one are made of aluminium with spacer inside

TL155

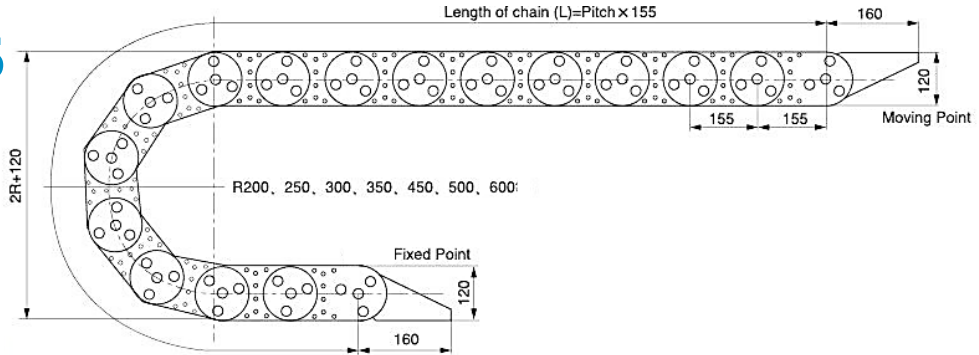

I Integral type,
II Separate type

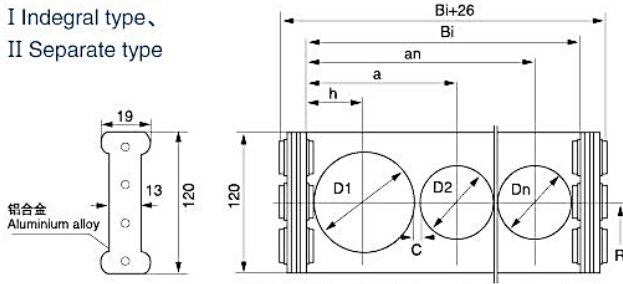

Supporting board I Integral type, II Separate type

III Frame type

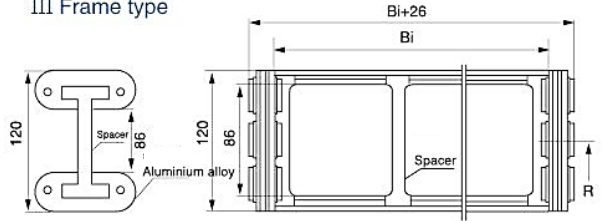

Supporting board III, Frame type

Standard connection

Standard connection

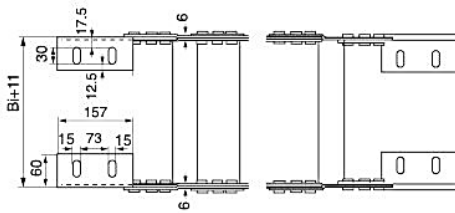

Manner of connection A

Manner of connection B

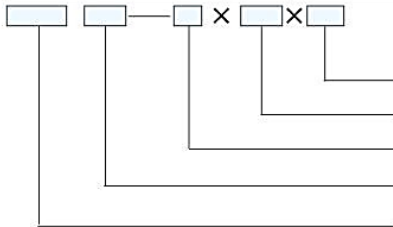
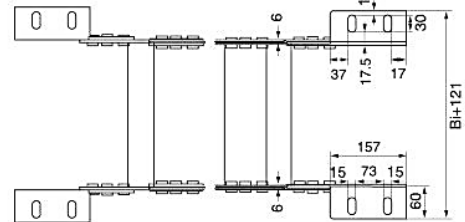

- L = length of drag chains
- Bi = Width of supporting board of drag chain
- Bending radius
- Supporting Board Type I、II、III
- Model No.

Example for an order
 Drag chain model number TL155, supporting board III type, bend radius R=200, supporting board width Bi=300 length L=8800
 Drag chain TL155III-200 x 300 x 8800
 I -type Integral type of support board
 II -type Separate type of support board
 III -type The upper one and the lower one are made of aluminium with spacer inside

unitmc.ru

TL180

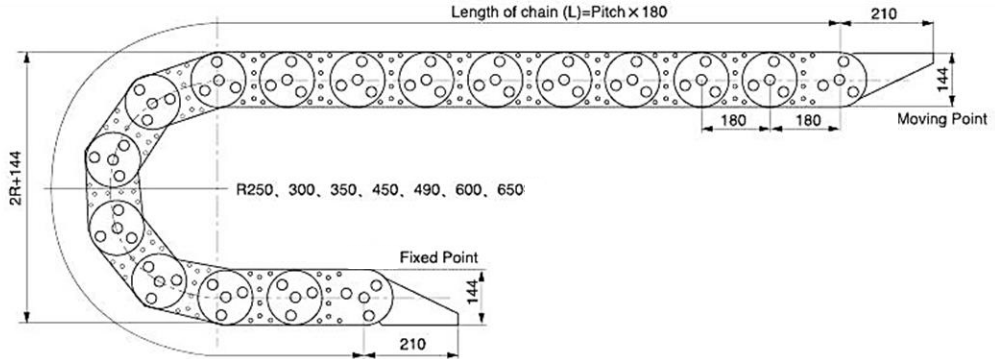

I Integral type,
II Separate type

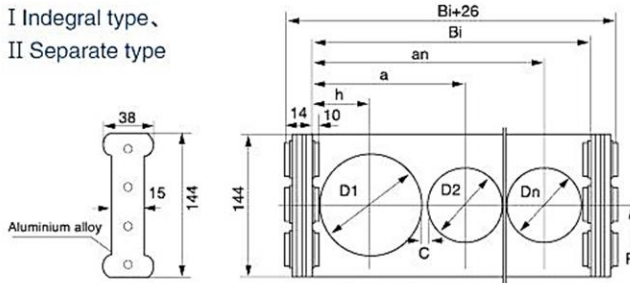

III Frame type

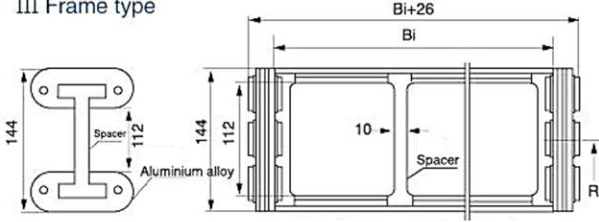

Supporting board I Integral type, II Separate type

Standard connection

Standard connection

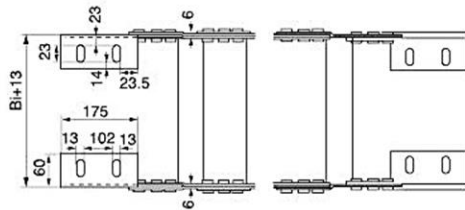

Manner of connection A

Manner of connection B

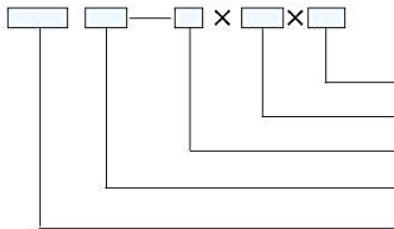
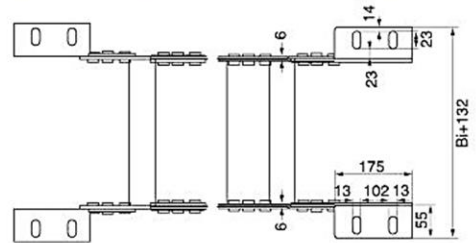

- L = length of drag chains
- Bi = Width of supporting board of drag chain
- Bending radius
- Supporting Board Type I、II、III
- Model No.

Example for an order
 Drag chain model number TL180, supporting board III type, bend radius R=250, supporting board width Bi=300 length L=9800
 Drag chain TL180III-250 x 300 x 9800
 I -type Integral type of support board
 II -type Separate type of support board
 III -type The upper one and the lower one are made of aluminium with spacer inside

unitmc.ru

TL225

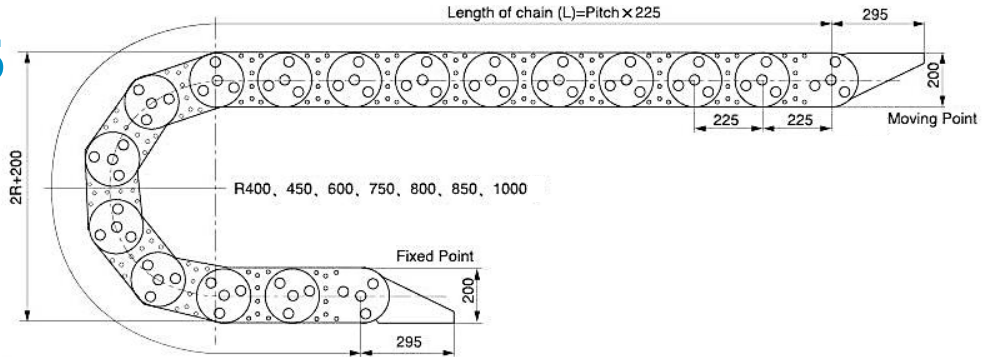

I Integral type,
II Separate type

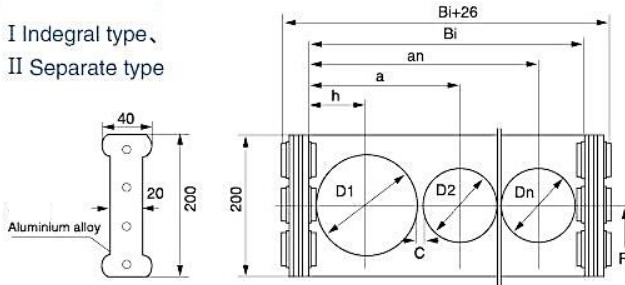

Supporting board I Integral type, II Separate type

III Frame type

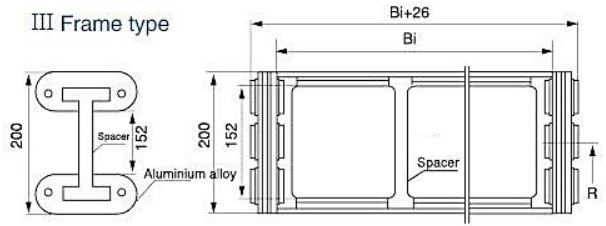

Supporting board III, Frame type

Standard connection

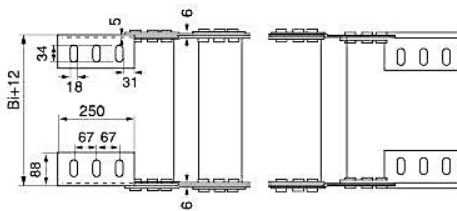

Standard connection

Manner of connection A

Manner of connection B

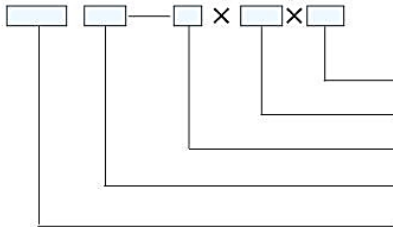
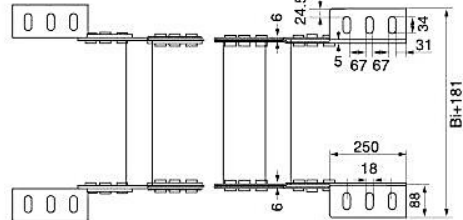

- L = length of drag chains
- Bi = Width of supporting board of drag chain
- Bending radius
- Supporting Board Type I、II、III
- Model No.

Example for an order

Drag chain model number TL225, supporting board III type, bend radius R=600, supporting board width Bi=400 length L=12000
 Drag chain TL225III-600 x 400 x 12000
 I -type Integral type of support board
 II -type Separate type of support board
 III -type The upper one and the lower one are made of aluminium with spacer inside

TL250

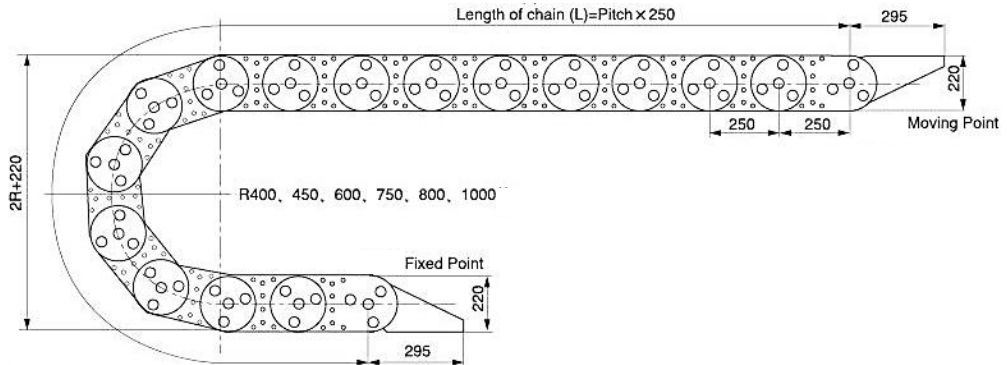

I Indegral type,
II Separate type

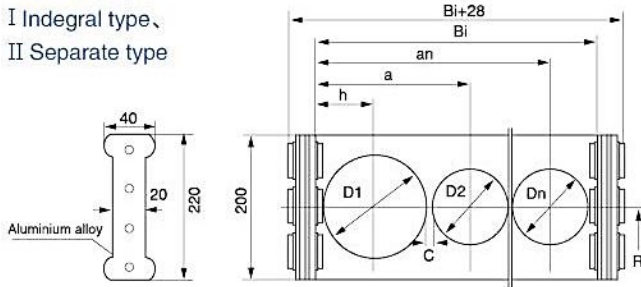

Supporting board I Indegral type, II Separate type

III Frame type

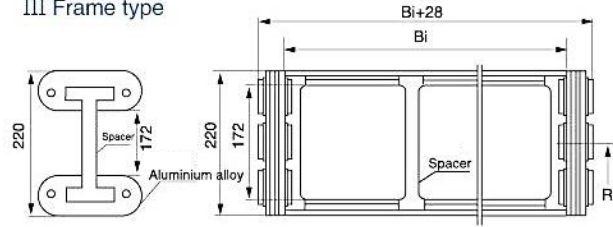

Supporting board III, Frame type

Standard connection

Standard connection

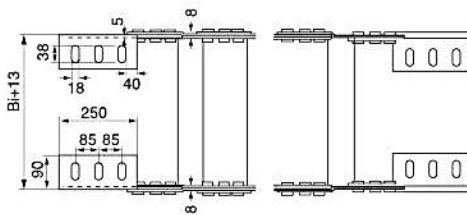

Manner of connection A

Manner of connection B

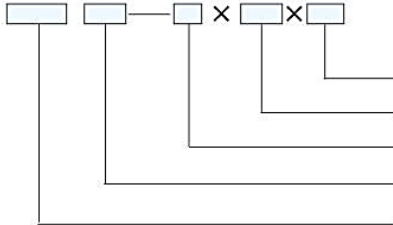
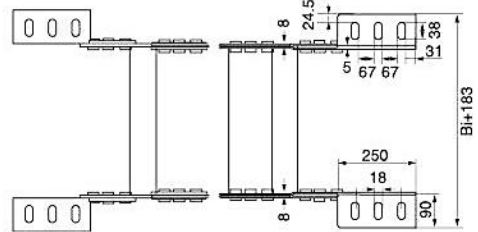

L = length of drag chains
Bi = Width of supporting board of drag chain
Bending radius
Supporting Board Type I、II、III
Model No.

Example for an order

Drag chain model number TL250, supporting board III type, bend radius R=600, supporting board width Bi=400 length L=12000
Drag chain TL250III-600 x 400 x 12000
I -type Integral type of support board
II -type Separate type of support board
III -type The upper one and the lower one are made of aluminium with spacer inside