

Driver Naming Rules

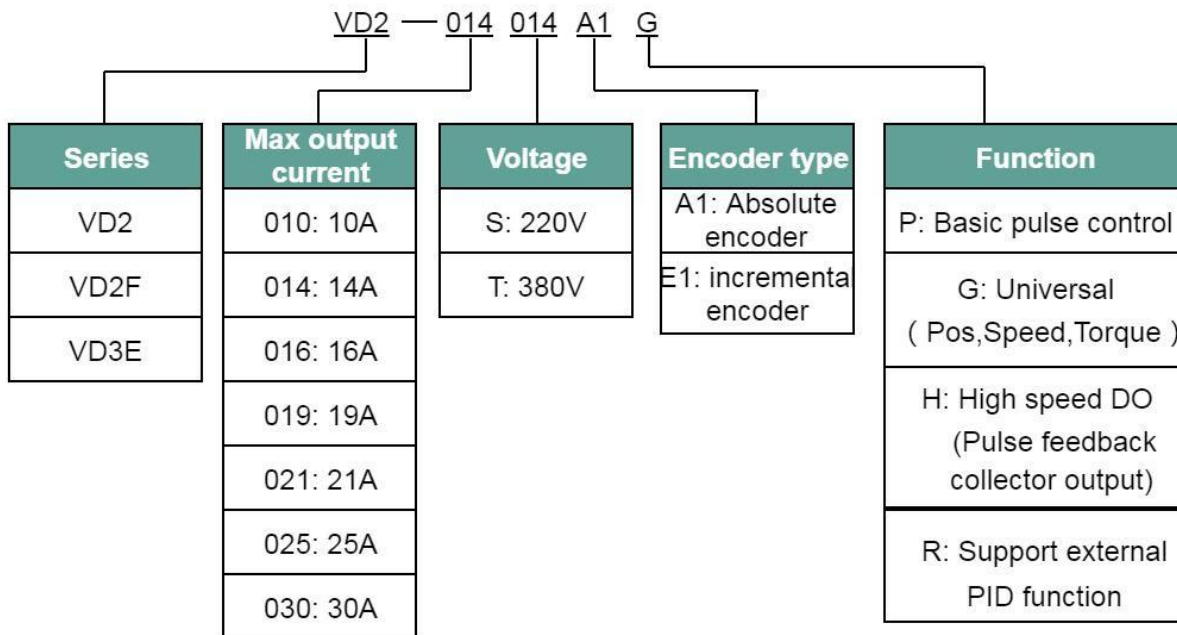

Motor Naming Rules

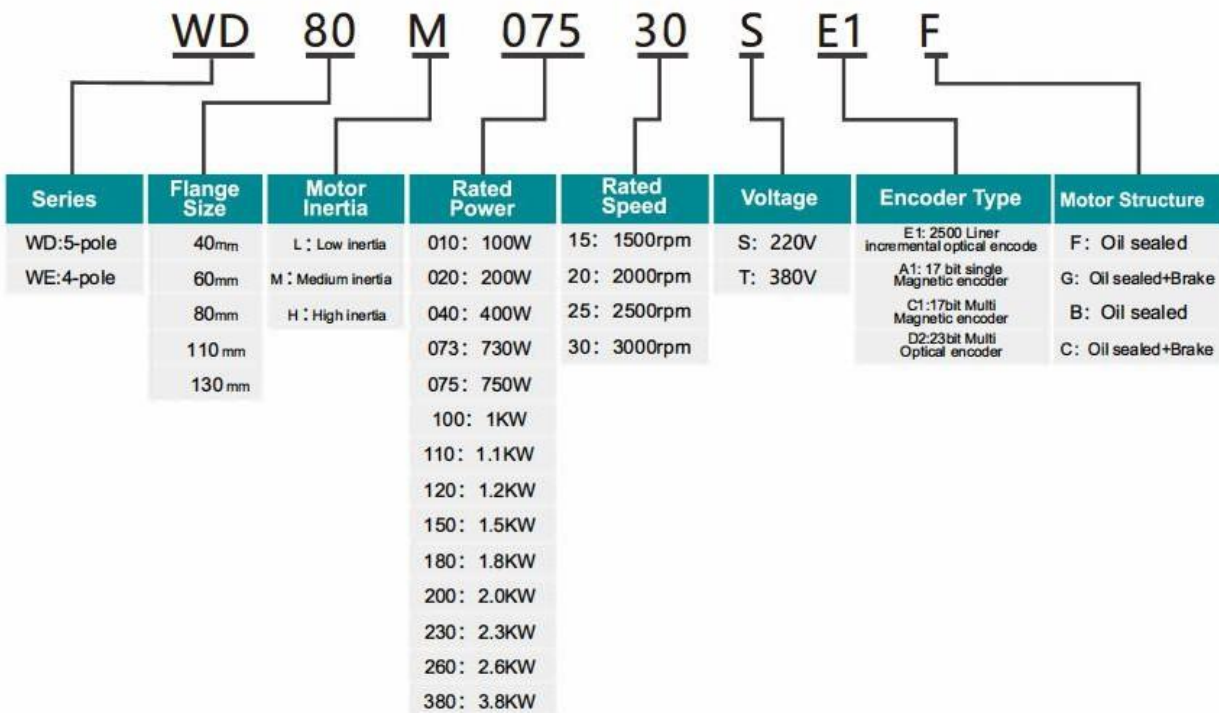

VD3E 17 bit Absolute Single-turn Magnetic Encoder

Flange Size	Motor Model	Drive Model	Rated Torque (N.m)	Rated Speed (rpm)	Voltage
40	WD40M-01030S-A1F	VD3E-010SA1G	0.318	3000	220V
60	WD60M-02030S-A1F-L	VD3E-010SA1G	0.64	3000	220V
60	WD60M-04030S-A1F	VD3E-010SA1G	1.27	3000	220V
60	WD60M-04030S-A1F-L	VD3E-010SA1G	1.27	3000	220V
80	WD80M-07530S-A1F	VD3E-014SA1G	2.39	3000	220V
80	WD80M-07530S-A1F-L	VD3E-014SA1G	2.39	3000	220V
80	WD80M-10030S-A1F	VD3E-014SA1G	3.18	3000	220V
80	WD80M-10030S-A1G	VD3E-014SA1G	3.18	3000	220V



VD3E 17 bit Absolute Multi-turn Magnetic Encoder

Flange Size	Motor Model	Drive Model	Rated Torque (N.m)	Rated Speed (rpm)	Voltage
60	WD60M-02030S-C1F-L	VD3E-010SA1G	0.64	3000	220V
60	WD60M-04030S-C1F	VD3E-010SA1G	1.27	3000	220V
60	WD60M-04030S-C1F-L	VD3E-010SA1G	1.27	3000	220V
80	WD80M-07530S-C1F	VD3E-014SA1G	2.39	3000	220V
80	WD80M-07530S-C1F-L	VD3E-014SA1G	2.39	3000	220V
80	WD80M-10030S-C1F	VD3E-014SA1G	3.18	3000	220V
80	WD80M-10030S-C1G	VD3E-014SA1G	3.18	3000	220V

VD3E 23 bit Absolute Multi-turn Optical Encoder

Flange Size	Motor Model	Drive Model	Rated Torque (N.m)	Rated Speed (rpm)	Voltage
60	WD60M-02030S-D2F-L	VD3E-010SA1G	0.64	3000	220V
60	WD60M-04030S-D2F	VD3E-010SA1G	1.27	3000	220V
60	WD60M-04030S-D2F-L	VD3E-010SA1G	1.27	3000	220V
80	WD80M-07530S-D2F	VD3E-014SA1G	2.39	3000	220V
80	WD80M-07530S-D2F-L	VD3E-014SA1G	2.39	3000	220V
80	WD80M-10030S-D2F	VD3E-014SA1G	3.18	3000	220V
80	WD80M-10030S-D2G	VD3E-014SA1G	3.18	3000	220V

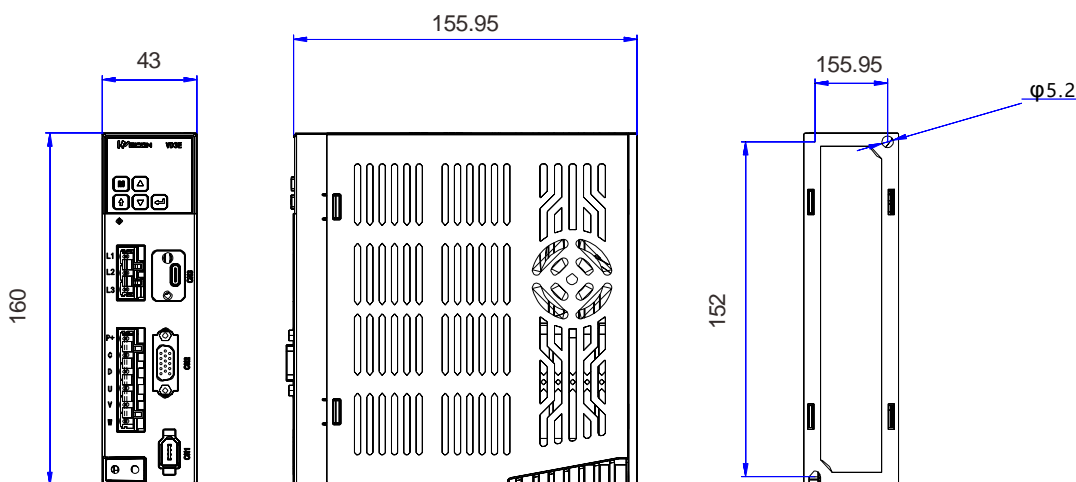

SPECIFICATION

Basic Specifications	Control Method	IGBT PWM control sine wave current drive
	Encoder Feedback	17bit/23bit absolute encoder
	Control Signal Input	6 DI inputs, select the input function according to the function code configuration
	Control Signal Output	3 DO outputs, select the output function according to the function code configuration
	Communication	USB interface. Function code parameter setting, status monitoring, waveform viewing, parameter self-tuning, etc. can be performed through upper computer
	Braking Resistor	Built-in braking resistor, support external braking resistor
General Function	Automatic Parameter Tuning	Automatic load inertia identification, automatic rigidity level and parameter self-tuning can be carried out through the cooperation of the upper computer
	Waveform View	The waveform of data such as real-time speed/torque/position deviation can be observed through the host computer
	Waveform Storage	The waveform acquisition frequency is 1KHz, and the original waveform data can be saved up to 10s
	Parameter import and	Support batch parameter import and export; support SDO download
	Vibration Suppression	Mechanical vibration can be suppressed by setting vibration suppression parameters
	Protective Function	Overvoltage, undervoltage, overcurrent, overspeed, overload, overheating, encoder failure, excessive position deviation, torque limit, speed limit, etc.
	Brake	Support output control
	Universal Control DI input	Servo enable (SON), fault and warning clear (A-CLR), forward drive prohibition (POT), reverse drive prohibition (NOT), emergency stop (E-STOP)
	General Control DO Output	servo ready(RDY), fault signal (ALM), warning signal (WARN), rotation detection (TGON), zero speed signal (ZSP), torque limit (T-LIMIT), speed limit (V- LIMIT), servo open state output (SRV-ST), servo brake output (BRK-OFF), communication VDO
EtherCAT	Communication	EtherCAT protocol
	Support Service	CoE (PDO, SDO)
	Synchronously physical layer	DC-distributed clock
	Baud rate	100 Mbit/s (100Base-TX)
	Duplex Mode	full duplex
	Topology	circular, linear
	Transmission	Shielded Cat 5e or better network cable.
	Transmission distance	The distance between two nodes is less than 100M (the environment is good and the cable is good).
	Number of Slave	The protocol supports up to 65535, and the actual use does not exceed 100.
	Frame Length	44 bytes~1498 bytes
	Process Data	A single Ethernet frame is up to 1486 bytes.
	Sync Jitter	<1us
	Distributed Clock	64 bit
	EEPROM Capacity	8kbit initialization data is written by the EtherCAT master station
	Control Mode	CSP, HM
	Sync Cycle	125μs

UnitMC.ru

40 Series Motor Specification

Motor model	WD40M-01030S-A1F
Rated power (kW)	0.1
Rated torque (N·m)	0.318
Rated speed (r/min)	3000
Brake	Optional
LA without Brake (mm)	74.8
LA with Brake (mm)	108

Remark:

A1-17 bit single Magnetic encoder; C1-17 bit Multi Magnetic encode; D2- 23bit Multi Optical encoder

F-sealed; G-sealed & Brake

-L: Connector type

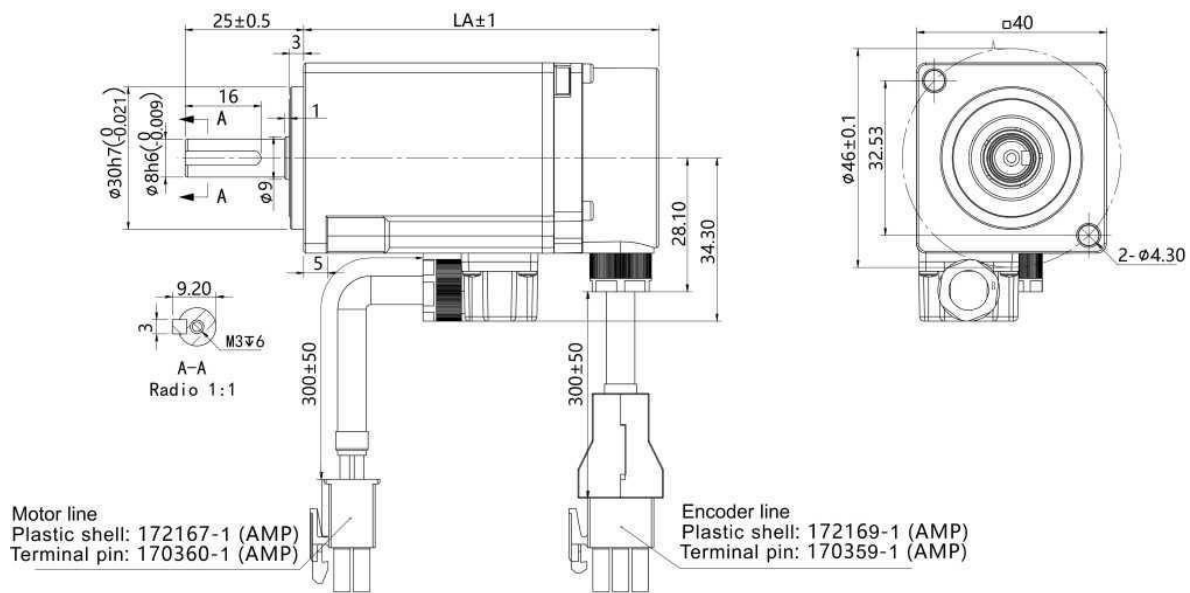

60 Series Motor Specification

Motor model	WD60M-02030S ^{★△}	WD60M-04030S ^{★△}
Rated power (kW)	0.2	0.4
Rated torque (N·m)	0.64	1.27
Rated speed (r/min)	3000	3000
Brake	Optional	Optional
LA without Brake (mm)	75	92
LA with Brake (mm)	99.5	116.5

Remark:

★ : A1-17 bit single Magnetic encoder; C1-17 bit Multi Magnetic encode; D2- 23bit Multi Optical encoder

△ : F-sealed; G-sealed & Brake

-L: Connector type

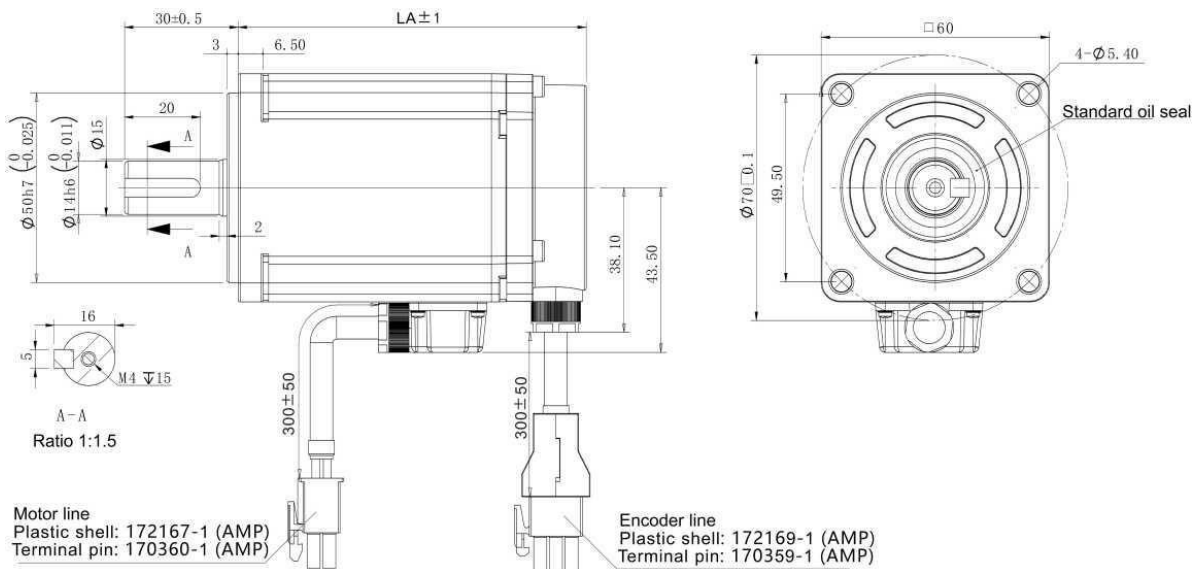

80 Series Motor Specification

Motor model	WD80M-07530S-A1F	WD80M-07530S-C1F	WD80M-07530S-D2F	WD80M-10030S ^{★△}
Rated power (kW)		0.75		1
Rated torque (N·m)		2.39		3.18
Rated speed (r/min)		3000		3000
Brake		Optional		Optional
LA without Brake (mm)		98.5		98.5
LA with Brake (mm)		128.5		132.5

Remark:

★: A1-17 bit single Magnetic encoder; C1-17 bit Multi Magnetic encode; D2- 23bit Multi Optical encoder

△: F-sealed; G-sealed & Brake

-L: Connector type

